

Effects of Cognitive Style on User Acceptance of Blogs and Podcasts

Nauman Saeed, Yun Yang, Suku Sinnappan
Swinburne University of Technology, PO Box 218, Hawthorn 3122, Victoria, Australia
E-mail: nsaeed, yyang, ssinnappan@swin.edu.au

Abstract

Blogs and podcasts are emerging Web technologies that have been adopted by educators to facilitate on-campus and distance education. However, little is known about user acceptance of these technologies. In this paper, we empirically test a theoretical model to examine the effects of individual's cognitive style on user acceptance of blogs and podcasts. We incorporated a course blog and series of lecture podcasts in a Web programming course and collected students' feedback on the technology usage. Empirical findings suggest that individual's cognitive style has significant effects on user acceptance of blogs and podcasts. However, students with innovative cognitive style are more likely to perceive these technologies as useful and easy-to-use as compared to their adaptor counterparts. Also, innovators perceive podcasts as more useful than blog whilst blog as more easy-to-use than podcasts.

1. Introduction

Emerging Web technologies like blogs and podcasts have gained wide-spread adoption among academics around the world [1]. Although several examples of academic blogging and podcasting are available, very little is known about user acceptance of these technologies; why people use (or don't use) them and what the significant predictors of their usage are? This study attempts to answer such questions by examining the effects of individual's cognitive style on the acceptance or usage of blogs and podcasts. We present an extended technology acceptance model (TAM) by including individual's cognitive style as determinant of technology use. Previous studies of technology acceptance have reported significant effects of cognitive style on individual's decision-making and usage of new technology [2-4].

We started by incorporating a course blog and series of lecture podcasts to a Web programming course with 197 on-campus students. At the end of the semester, students were asked to complete an online survey about their cognitive style and technology acceptance.

The data collected from the survey were used to validate the proposed model using the PLS (Partial Least Squares) approach. Findings suggest that individual's cognitive style have significant effects on user acceptance of experimented technologies.

2. Background

2.1. Blogs and podcasts in education

Blogging has received increased attention in both professional and academic circles as it becomes more prevalent (Pew Internet and American Life Project 2005; <http://www.pewinternet.org>). A number of studies have shown benefits of using blogs in academic settings. For example, Lin et al., reported that blogs successfully contributed to students' online engagement [5]; Maag reported that students shared their learning experiences and express their thoughts to the instructor and peers through course blogs [6]. Dickey reported that blogs spark reflective learning and satisfaction [7]. Despite these there are some conflicting results about effectiveness of blogs. For example, many blog sites were claimed to be abandoned soon after their creation [8]; or found to be unproductive in terms of interactivity among students [9]. Thus, it is important to know what motivates participants to use blogs.

Like blogs, several examples of educational podcasting are also available. For example, the Duke iPod first-year experience project in which iPods were used for course content dissemination, classroom recording, field recording, study support, and file storage and transfer [10]. Podcasting is also known to be more flexible and effective than traditional use of Websites and printed handouts [11] or even text books or students' own notes [12]. It is also found that podcasts advanced learning and improved students' understanding of the lecture material [13]. Despite these benefits of educational podcasting, very little empirical research has been carried out about the factors driving usage of academic podcasting. Thus, this study also focuses on investigating significant predictors of podcast usage.

2.2. Technology acceptance theory

In IS research, several theoretical models and frameworks attempt to explain or predict a person's decision to accept a new technology [4]. Of particular importance is the technology acceptance model (TAM), a widely used model originally developed by Davis and his colleagues [14] to explain or predict individuals' acceptance of computer-based systems in various scenarios and organizational contexts [4]. TAM posits that user perceptions of usefulness and ease-of-use determine attitudes or intentions towards using the system, which finally leads to actual system use. Several researchers have validated TAM for a variety of target applications including word processors, e-mail, spreadsheets [15], Web-browsers [16], Web-based learning systems [17], and multimedia learning systems [18]. In this study, we employ TAM to test the user acceptance of blogs and podcasts by including cognitive style as antecedent of perceived usefulness and ease-of-use of the two technologies.

2.3. Influence of individual's cognitive style on technology acceptance

Cognitive or learning style is a distinctive and habitual manner of acquiring knowledge, skills or attitudes through study or experience [19]. Existing studies show that matching cognitive style with teaching methods is advantageous to academic achievements [20, 21]. Similar studies involving technology acceptance have shown credible link between cognitive style and individual's decision making [2, 3]. Here we focus on investigating the effects of cognitive style on user acceptance of blogs and podcasts. Cognitive style has been categorized according to different classification schemes. In this study, we use adaption – innovation theory as it has been applied broadly in social psychology and other disciplines. This theory states that a person's cognitive style in a decision-making context can be classified as adaptive or innovative on a continuum anchored at 'extremely adaptive' and 'extremely innovative' [22].

3. Research hypotheses and model

3.1. TAM hypotheses

Perceived usefulness and perceived ease-of-use are basic TAM constructs. In general, perceived usefulness reflects an individual's subjective estimation of the job performance enhancement that is likely to result from the use of a new technology, whereas perceived ease-

of-use refers to the degree to which he or she expects the use of technology to be free of effort [14]. Both of these constructs constitute a significant influence on an individual's intention to use a technology or system [23]. We follow this trend and hypothesize the following:

- H1. The perceived ease-of-use (PEU) of blog / podcast will have a positive effect on behavioral intention (BI) to use blog / podcast.
- H2. The perceived ease-of-use (PEU) of blog / podcast will have a positive effect on perceived usefulness (PU) of blog / podcast.
- H3. The perceived usefulness (PU) of blog / podcast will have a positive effect on behavioral intention (BI) to use blog / podcast.

3.2. Influence of cognitive style

As mentioned earlier, we use adaption - innovation theory to examine the effects of individual's cognitive style on technology acceptance. In general, adaptors prefer operating within a consequently agreed upon paradigm and often are skilled at initiating changes to improve or adapt current methods of doing things while innovators prefer working outside an agreed upon paradigm and often effectively initiate changes that manifest different ways of doing things [4]. Based on this we hypothesize the following:

- H4. Cognitive style (CS) will have an important effect on perceived ease-of-use (PEU); specifically, innovators are more likely to perceive blog / podcast as easy-to-use as compared to adaptors.
- H5. Cognitive style (CS) will have an important effect on perceived usefulness (PU); specifically, innovators are more likely to perceive blog / podcast as useful as compared to adaptors.

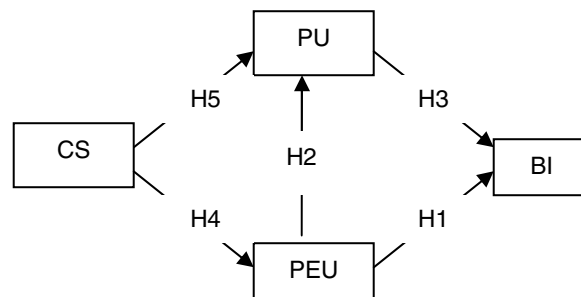

Figure 1. Research model for user acceptance of blog / podcast

On the basis of above hypotheses, we present an extended TAM including individual's cognitive style

as significant predictor of user acceptance of blogs and podcasts, as shown in Figure 1.

4. Research methodology

4.1. Experiments with blog and podcast

At the start of semester 2 in 2008, students of a first year Web programming course were introduced to the course blog and lecture podcasts. Students were advised to make frequent blog postings on course related discussions such as issues raised in class, or about assignments and examination. Audio and video recordings of all lectures were also made available. Students could retrieve the lecture podcasts in three different formats: manual download, automatic subscription and online viewing. An online survey was conducted at the end of the semester to collect student's cognitive style data and their opinions on the usage and acceptance of experimented technologies.

4.2. Measures

The scales for perceived ease-of-use (PEU), perceived usefulness (PU) and behavioral intention (BI) were adopted from [14] including 4 items (PEU1-4), 6 items (PU1-6) and 3 items (BI1-3) respectively. All above items were measured on a seven-point Likert scale, ranging from 1 (strongly disagree) to 7 (strongly agree). The individual's cognitive style were measured on a five point scale using Kirtons' Adaptive-Innovation (KAI) inventory [24] including 32 items (CS1-32). The survey questionnaire is not included due to space limit.

5. Results

The research model was tested using PLS. PLS is considered as a powerful tool in analysing structural models involving multiple constructs and multiple indicators and has been used in other technology acceptance studies such as [25] and [26].

5.1. Demographics

With a total number of 197 students in the class, 187 responded to our survey with a response rate of 94.9%, including 162 males and 25 females. The mean age of the participants was 27, ranging from 17-40. Nearly 66% had more than six months blogging experience while the major reason of blogging by the majority (67%) was 'Study'. Nearly 50% reported at least six months experience of podcasts while the

major use of podcasting by the majority (62%) was 'Study'.

5.2. Data validity and reliability

Table 1 presents the summary of all measurement scales including factor loading (FL) values, composite reliability (CR) and average variance extracted (AVE) for both technologies (blog and podcasts). The factor loadings provided the evidence for convergent validity as all constructs loaded greater than the threshold of 0.50 as suggested by [27]. Internal consistency also appeared significant for all of our constructs since the composite reliability values exceeded the minimum of 0.70 as suggested by [28].

Table 1. Summary of measurement scales

	Constructs	FL	CR	AVE
BLOG	PEU (1-4)	.71	.76	.51
	PU (1-6)	.76	.90	.59
	CS (1-32)	.65	.76	.50
	BI (1-3)	.83	.87	.70
PODCAST	PEU (1-4)	.71	.81	.51
	PU (1-6)	.77	.90	.60
	CS (1-32)	.66	.75	.50
	BI (1-3)	.84	.88	.71

Discriminant validity was met using the Fornell and Larcker test [29]. The procedure involves computing the square root of the AVE of each construct, which should exceed the correlation shared between the construct and other constructs in the model. Table 2 shows that square roots (in bold) of all AVEs (on the diagonal) are greater than the cross-correlations of all other constructs. Thus all our constructs demonstrated a good degree of validity and reliability.

Table 2. Discriminant validity of constructs

		PEU	PU	CS	BI
BLOG	PEU	.70			
	PU	.45	.77		
	CS	.40	.34	.71	
	BI	.38	.55	.34	.84
PODCAST	PEU	.71			
	PU	.53	.77		
	CS	.34	.37	.71	
	BI	.45	.54	.40	.84

5.3. Hypotheses and model testing

Figures 2 and 3 summarize the results of hypotheses testing for course blog and lecture podcasts respectively. We found a direct positive effect of perceived ease-of-use (PEU) on behavioral intention

(BI) and perceived usefulness (PU) for both technologies, thus supporting hypotheses H1 and H2. However, these two relationships appeared stronger for lecture podcasts than the blog. Similarly, hypothesis H3 appeared significant for both technologies but relatively stronger for the blog than podcasts. Cognitive style showed significant effects on PU and PEU of both technologies; positive path coefficient values showed that innovators perceived the blog and lecture podcasts as more useful and easy-to-use than adaptors thus supporting hypotheses H4 and H5 respectively.

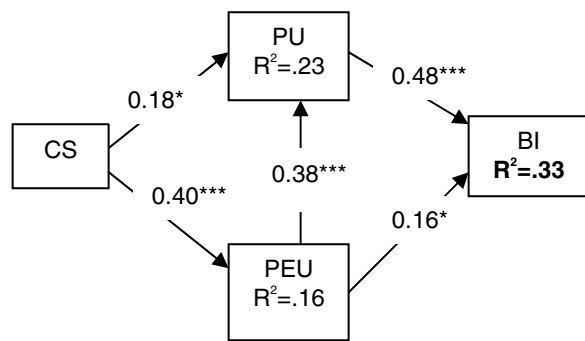

Figure 2. PLS findings - acceptance of blog

Notes: *Path coefficient significant at the 0.5 level; ** at the 0.01 level; *** at the 0.001 level

However, the impact of cognitive style on ease-of-use appeared stronger than that of usefulness, implying that innovators perceived the blog and lecture podcasts as more easy-to-use than useful.

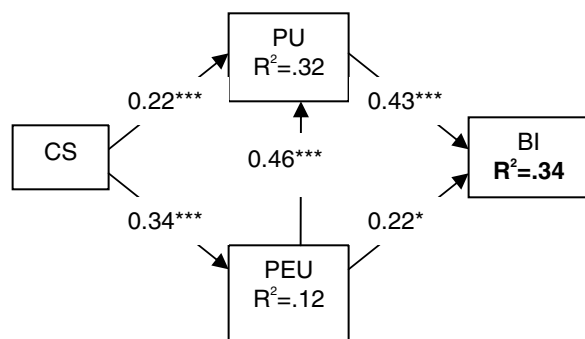

Figure 3. PLS findings - acceptance of podcast

Notes: *Path coefficient significant at the 0.5 level; ** at the 0.01 level; *** at the 0.001 level

Thus all hypothesized relationships formulated at the start are confirmed by the data. Figures 2 and 3 also show that our model explains 33% of the students' intention to use the blog while 34% of intentions to use

podcasts, which is consistent with similar studies of technology acceptance addressed in [25, 26, 30].

6. Discussion

This study is primarily focused on examining the effects of cognitive style on user acceptance of academic blogging and podcasting. To achieve this, we presented a theoretical model based on TAM including cognitive style as an antecedent of perceived usefulness and perceived ease-of-use (of the two technologies). All five hypotheses formulated at the start were confirmed by our data thus supporting our model. Findings suggest that individual's cognitive style have significant effects on the perceived usefulness and perceived ease-of-use of blog and podcasts which in turn leads to users' intentions to use these technologies. The positive and highly significant path coefficient values imply that the more a student is innovative the more he or she is likely to perceive blog or podcast useful and easy-to-use. However, the effect of cognitive style on perceived ease-of-use appears stronger than perceived usefulness, for both technologies. These results further suggest that innovators perceive new technology as easier-to-use than their adaptors counterparts, which is consistent with the findings reported in [4]. Our findings also suggest that innovators perceive course blog as more easy-to-use than lecture podcasts. This is consistent with [31] and reiterates the need for an easy-to-use interface in order to increase blog usage. It is also evident that innovators perceive lecture podcasts as more useful than the course blog. The usefulness of podcasting is also echoed by several other studies such as [13] and [12] where students found podcasts to be extremely useful, effective, efficient and easily received learning tool for lecture revision. These findings have implications for educators; they should target students with innovative cognitive styles to be early adopters and utilize them as a catalyst for technology dissemination in the class. Our model explains 33% and 34% of users' intentions to use blogs and podcasts respectively, which are comparable but relatively lower than some previous studies. This highlights the need to investigate other determinants of user acceptance of blogs and podcasts in order to increase their usage.

7. Conclusion and future work

The study provided a useful insight into user acceptance of blogs and podcasts by examining the effects of individual's cognitive style on technology acceptance. A combination of course blog and lecture

podcasts was used to facilitate the delivery of a Web programming course. Students' feedback helped to validate a structural model which was presented to examine the user acceptance of the two technologies. Statistical analyses provided support for our model. Students' cognitive style appeared to have significant effects on the acceptance of course blog and lecture podcasts. However further research would be needed to investigate other significant determinants of user acceptance in order to utilize blogs and podcasts as effective teaching and learning tools.

8. References

- [1] M. Weller, C. Pegler, and R. Mason, "Use of innovative technologies on an e-learning course " Internet and Higher Education, vol. 8, 2005.
- [2] G. Dickson, W. G. DeSanctis, and D. McBride, J, "Understanding the effectiveness of computer graphics for decision support: a cumulative experimental approach," Communications of the ACM, vol. 29, pp. 40-47, 1986.
- [3] A. Harrison, W and R. Rainer, K, "The influence of individual differences on skill in end-user computing," Management Information Systems, vol. 9, pp. 93-111, 1992.
- [4] I. Chakraborty, P. J.-H. Hu, and D. Cui, "Examining the effects of cognitive style in individuals' technology use decision making," Decision Support Systems, vol. 45, pp. 228-241 2008.
- [5] J. Lin W, H. Yueh, P, Y. Liu, L, M. Murakami, K. Kakusho, and M. Minoh, "Blog as a tool to develop e-learning experiences in an international distance course," in ICALT, 2006.
- [6] M. Maag, "The potential use of 'Blogs' in nursing education," CIN: Computers, Informatics, Nursing, vol. 23, pp. 16-24, 2005.
- [7] M. D. Dickey, "The impact of blogs on student perceptions of isolation and alienation in a Web-based distance learning environment," Open Learning, vol. 19, pp. 279-291, 2004.
- [8] B. Arnold, "Blog statistics and demographics," 2008.
- [9] M. Divitini, O. Haugalokken, and E. M. Morken, "Blog to support learning in field: lessons learned from a fiasco," in ICALT, Kaohsiung, Taiwan., 2005, pp. 219-221.
- [10] Y. Belanger, "Duke iPod First Year Experience: Final Evaluation Report," Duke University, USA2005.
- [11] A. Chan and M. J. W. Lee, "An MP3 a day keeps the worries away," in Student Experience Conference, Wagga Wagga, Australia, 2005, pp. 59-71.
- [12] C. Evans, "The effectiveness of m-learning in the form of podcast revision lectures in higher education," Computers and Education, vol. 50, pp. 491-498, 2007.
- [13] S. B. Bongey, G. Cizadlo, and L. Kalnbach, "Explorations in course-casting: podcasts in higher education," Campus-wide Information Systems, vol. 23, pp. 350-367, 2006.
- [14] F. D. Davis, R. P. Bagozzi, and P. R. Warshaw, "User acceptance of computer technology: a comparison of two theoretical models," Management Science, vol. 35, pp. 982-1003, 1989.
- [15] A. L. Lederer, D. J. Maupin, M. P. Sena, and Y. Zhuang, "TAM and the World Wide Web," Decision Support Systems, vol. 29, pp. 269-282, 2000.
- [16] M. G. Morris and A. Dillon, "The influence of user perceptions on software utilization: Application and evaluation of a theoretical model of technology acceptance," Journal of IEEE Software, vol. 14, pp. 56-75, 1997.
- [17] Leila Halawi and R. McCarthy, "Measuring faculty perceptions of Blackboard using the TAM," Issues in Information Systems, vol. 8, pp. 160-165, 2007.
- [18] R. Saade, F. Nebebe, and W. Tan, "Viability of TAM in multimedia learning environments: A comparative study," Knowledge and Learning Objects, vol. 3, pp. 175-184, 2007.
- [19] E. Sadler-Smith, "Learning Styles and instructional Design," Innovations in Education and Training International, vol. 33, pp. 185-193, 1996.
- [20] P. Smith and J. Dalton, "Accommodating learning styles: Relevance and good practice in vocational education and training," NCVET, Australia2005.
- [21] N. Saeed and Y. Yang, "Using learning styles and preferences to incorporate emerging e-learning tools in teaching," in ICALT'08, Santander, Spain, 2008, pp. 967-971.
- [22] M. J. Kirton, "Adaptors and innovators: a description and a measure," Applied Psychology, vol. 61, pp. 622-629, 1976.
- [23] Q. Ma and L. Liu, "The technology acceptance model: a meta-analysis of empirical findings," Organizational and End User Computing, vol. 16, pp. 59-72, 2004.
- [24] R. P. Bagozzi and G. R. Foxall, "Construct validity and generalizability of the KAI Inventory," European Journal of Personality, vol. 9, pp. 185-206, 1995.
- [25] E. M. Raaij and J. J. L. Schepers, "The acceptance and use of a virtual learning environment in China," Computers and Education, vol. 50, pp. 838-852, 2008.
- [26] Y. Y. Mun and Y. Hwang, "Predicting the use of web-based IS: self-efficacy, enjoyment, learning goal orientation, and TAM," Human-Computer Studies, vol. 59, pp. 431-449, 2003.
- [27] R. Peterson, "A meta-analysis of variance accounted for and factor loadings in exploratory factor analysis," Marketing Letters, vol. 11, pp. 261-275, 2000.
- [28] J. C. Nunnally and I. H. Bernstein, Psychometric theory. New York: McGraw Hill, 1994.
- [29] C. Fornell and D. F. Larcker, "SEM with unobservable variables and measurement error: Algebra and statistics," Marketing Research, vol. 18, pp. 382-388, 1981.
- [30] R. Saade and B. Bahli, "The impact of cognitive absorption on perceived usefulness and perceived ease of use in on-line learning: an extension of the TAM," Information and Management, vol. 42, pp. 317-327, 2005.
- [31] C.-L. Hsu and J. C.-C. Lin, "Acceptance of blog usage: The roles of technology acceptance, social influence and knowledge sharing motivation," Information and Management, vol. 45, pp. 65-74, 2008.