

Drift Capacity of Lightly Reinforced Soft Storey Structures

A. Wibowo, J.L. Wilson, E.F. Gad

Centre for Sustainable Infrastructure, Faculty of Engineering and Industrial Sciences, Swinburne University of Technology, Victoria, 3122, Australia

N.T.K. Lam

Department of Infrastructure Engineering, University of Melbourne, Victoria, 3010, Australia.

ABSTRACT: Lightly reinforced concrete columns and soft storey configurations are prevalent in many old buildings in regions of lower seismicity. This type of structure is believed to have a very low lateral load and drift capacity from a conventional design perspective. Furthermore, the application of design standards in low and moderate seismic regions such as Australia, results in most of the lightly reinforced structures being deemed unsafe in an earthquake. Therefore, an earthquake damage reconnaissance, experimental field test, and laboratory study of non ductile columns has been undertaken to examine the drift capacity and failure mechanism of such columns.

Firstly, a field reconnaissance was conducted in China after the Wenchuan Earthquake in 2008, particularly in regions with similar design intensity MMI VI to VIII experienced in Australia. A comparison between the Wenchuan Earthquake and the characteristics of design earthquakes in Australia was made to provide insight for the development of future design standards and for the assessment of existing buildings in Australia.

A unique experimental field testing of a precast soft storey building in Carlton Melbourne was then undertaken. Four tests were conducted to measure the drift capacity and load-deflection behaviour of such buildings. The experimental results together with a comparison with theoretical predictions showed that the precast columns with weak connection had significant displacement capacity controlled by the column rocking irrespective of strength degradation.

Lastly, a laboratory research project has been undertaken to investigate the collapse behaviour of insitu lightly reinforced concrete columns. The effect of variation of axial load ratio and longitudinal reinforcement ratio on flexural, yield penetration, and shear displacement as components of the drift capacity were observed. Interesting outcomes showed that lightly reinforced concrete columns were able to sustain lateral drift considerably greater than the code recommendations, whilst the present shear capacity predictions tended to overestimate the nominal shear strength of the column.

KEYWORDS: Drift capacity, lightly reinforced concrete, seismic performance, force-displacement relationship

1. INTRODUCTION

Lightly reinforced concrete columns are prevalent in many old buildings and common in current detailing practice in regions of lower seismicity. This type of structure is believed to have a very low lateral load and drift capacity from a conventional design perspective. However, many post earthquake investigations (Otani 1997, Wibowo et.al 2008) show that the primary cause of reinforced concrete building collapse during earthquakes is the loss of vertical-load-carrying capacity in critical building components leading to progressive vertical collapse, rather than loss of lateral-load capacity (Ghannoum et.al, 2008). Therefore, an investigation and laboratory study of non ductile columns is needed to examine the drift capacity and the primary parameters that contribute to the loss of column axial-load capacity.

A field reconnaissance was conducted in Sichuan, China, in order to study the damage building pattern due to the 2008 Wenchuan earthquake (Wibowo et.al, 2008). Many buildings in Sichuan had inadequate construction quality including insufficient reinforcement, poor detailing and poor quality concrete. Some of the poor detailing included lack of reinforcement in the beam column joint (Figure 1), lack of transverse ties in the beam and column and lack of an embedment length for reinforcement anchorage. Particular observations were conducted on soft storey damage structures (Figure 2 and 3) that occurred in Chengdu and Mianyang with intensity range MMI VI to MMI VIII for comparison with Australian conditions.

A “soft storey” is characterized by one storey of the building being much weaker and more flexible than the adjoining stories. Consequently deformation and damage are concentrated at this level, with the column that must resist the gravity loading also being forced to deform laterally. Subsequent failure of the column results in a soft storey collapse, which is one of the most common failures from severe earthquake ground shaking. Poor concrete quality and poor seismic detailing will further limit the drift capacity of columns and encourage soft storey collapse. In the Chengdu and Mianyang region, no soft storey buildings were observed to have collapsed, whilst in Dujiangyan and Ying Xiu many buildings were significantly damaged with drifts up to 7.5% measured (Figure 2 and 3) which is much higher than the code recommendation of about 0.5%.



Figure 1. Poor beam-joint connection



Figure 2. Soft first storey of 6-storeys building in Dujiangyan with drift of about 7.5%



Figure 3. Soft storey damage of second storey with drift of about 5.6% in Dujiangyan

2. EXPERIMENTAL FIELD-TESTING OF PRECAST SOFT STOREY BUILDING

In order to obtain drift capacity and load-deformation behaviour of actual buildings in an Australian context, a unique research project has been conducted, which involves experimental field testing of a four-storey soft storey building in Melbourne [Bamare et.al 2008, Wibowo et.al 2009]. The soft-storey consisted of precast concrete columns with relatively weak connection at each end. The objective of the experimental investigation was to study the load-deflection behaviour and collapse modelling of soft storey buildings when subjected to lateral loading.

2.1. Experimental Procedure

Four push-over field tests were undertaken on a ground floor bay consisting of four columns as shown in Figure 4. It was decided for safety reasons to demolish the upper levels of the building to first floor level to create the test bay without damaging the portal frames (Figure 5). Four test bays were selected for testing and were separated from each other by saw cutting the floor slab between adjacent bays. A steel frame was constructed at first floor level and positively secured to the slab and beams to provide support for the kentledge and to provide anchorage for the lateral load to be applied to the soft storey bay. Horizontal loads were applied in both the strong and weak directions via steel tension ties and hydraulic jacks secured to a piled reaction located at some distance from the test bay as shown schematically in Figure 6. The four columns in a typical bay would typically support around 200 tonnes of dead load plus a live load from the upper storeys. However, it was not deemed practical to load the frame with the full gravity load and consequently only 50 tonnes of kentledge in the form of precast 'jersy barriers' was added to provide a reasonable loading.

The slab on ground provided significant restraint to the columns at ground floor level and consequently two tests were conducted with the ground slab intact and the other two tests with the slab cut away to prevent restraint.

2.2. Experimental Result and Theoretical Prediction Analysis

A comprehensive set of results have been obtained from the experimental testing and a sample load displacement curve for all test are shown in Table 1 and Figure 7. The displacement shown corresponds to the lateral displacement at the slab level and the load is the total lateral force imposed on the structure. In the strong direction, the majority of the deformations were concentrated at the end connections, with gaps opening at the foundation and beam interfaces. This was a clear indication that the columns were significantly stronger than the connections. In the weaker direction, deformations were concentrated at the foundation interface and at the interface of the portal beams and the first floor slab.

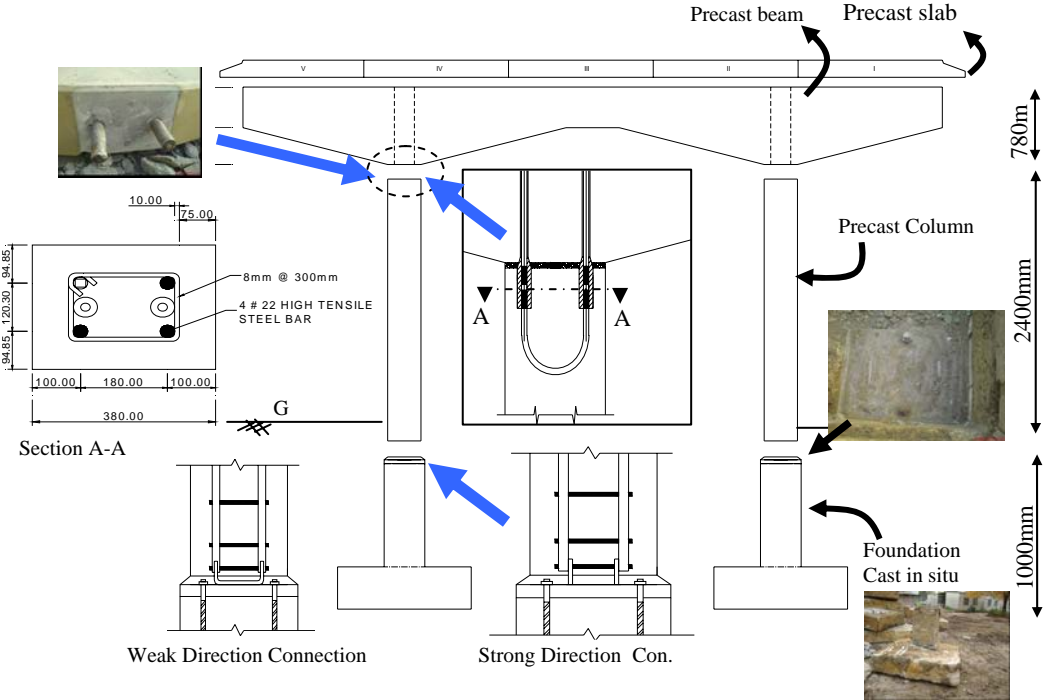

Figure 4 Structural details of the Bay



Figure 5. Demolition process of the buildings.

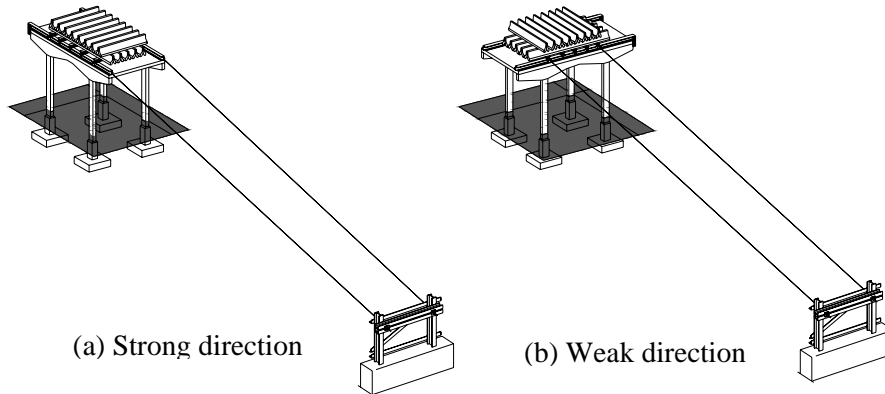

Figure 6 Test set-up configurations

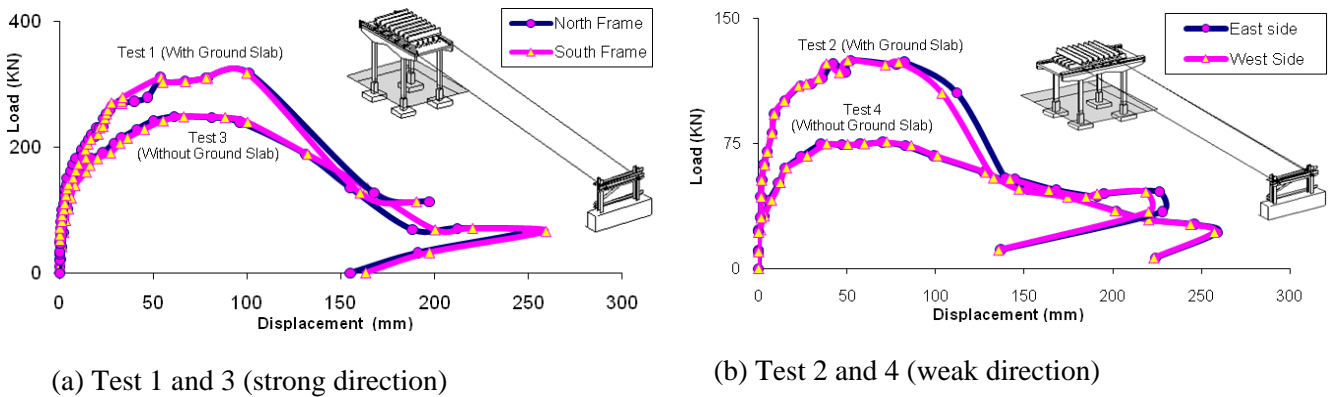

Figure 7 Experimental load-deflection results

Table 1 Summary of maximum load, displacement and drift of all tests

Orientation	Test	Maximum Load (kN)	Maximum Load (% self weight)	Maximum Displacement (mm)	Maximum Drift (%)
Strong Direction	Test 1	310	52	200	5.9
	Test 3	250	42	255	7.5
Weak Direction	Test 2	125	21	225	6.6
	Test 4	75	12	260	7.6

The soft storey column was found to have significant displacement capacity irrespective of strength degradation (Figure 7). An important outcome of this work is that the columns maintained their gravity load carrying capacity at a lateral displacement of about 260mm or a drift capacity of about 8% under these quasi-static conditions. Interestingly, the weak column/foundation and column/beam precast connections allowed the columns to rock about their ends, greatly enhancing the displacement capacity of the soft storey system compared with rigid end column connections more typical of in-situ construction. Moreover, the ground slab provided significant restraint to the frame, especially in the weak direction. The increase of load capacity due to the existence of ground slab is about 25 percent in the strong direction and about 67 percent in the weak direction.

A theoretical prediction analysis was undertaken to estimate collapse behaviour of such structure (Wibowo et.al, 2010). It can be shown analytically that the load-deflection behaviour of the strong direction was mostly affected by the connection strength at the top of the column, whereas the gravity load rocking mechanism dominated the load-deflection behaviour in the weak direction.

The experimental results together with a comparison with theoretical predictions showed that soft storey columns had significant displacement capacity controlled by the column width irrespective of strength degradation.

3. EXPERIMENTAL LABORATORY TEST OF INSITU COLUMNS

This section describes the seismic performance assessment of insitu lightly reinforced concrete columns based on results from laboratory testing. The experimental testing of four column specimens has been undertaken. All four columns were subjected to quasi-static cyclic lateral load. The specimens represent some of the most commonly found detailing buildings in developing countries and/or in low-to-moderate seismic regions. These columns are characterized by: moderate aspect ratio, lightly reinforced, limited lateral confinement and moderate axial load ratio.

3.1 Specimen Design

Four column specimens were designed to represent a prototype of the non-ductile reinforced concrete columns of old buildings in low-to-moderate seismic regions. The two parameters varied were the axial load and longitudinal steel reinforcement ratio. The specimens were 270×300mm cantilever columns with a height (to the application of lateral load) of 1200 mm. All specimens had Grade 500 reinforcing bars with two specimens reinforced with four N12, and the other two specimens reinforced with four N16 (longitudinal reinforcing ratio of 0.56% and 1% respectively). In all cases, R6 stirrups were used at 300mm spacing corresponding to a transverse reinforcement ratio of 0.07% (by area) which is less than minimum lateral reinforcement required by AS3600. All perimeter ties had 135° hooks with just half of the required length of current design codes. The concrete cover was 20mm, whilst the specified concrete compressive strength and steel yield stress were 20 MPa, 536 MPa for main bars and 362 MPa for stirrups, respectively (details are presented in Table 2 and Figure 8).

3.2 Test Setup

The drift capacity of concrete columns is made up of flexural, yield penetration, and shear components which were measured using LVDTs and strain gauges. The axial displacement was also measured to detect loss of axial-load capacity. Displacements were measured using eighteen linear variable displacement transducers (LVDT), as shown in Figure 10a. The LVDT was arranged to measure axial displacement (no. 18), total lateral displacement (no. 1-5), flexural displacement (no. 6-11) and shear deformation (no. 12-17), whilst sixteen strain gauges were installed on the reinforcement to measure the longitudinal and transverse strains (Figures 10b). Three strain gauge locations were used; one level for checking yield penetration length; the second level at the footing-column surface for measuring maximum strain needed for yield penetration; and the third level was at the middle of predicted plastic hinge length.

The axial load was applied and maintained using a hydraulic jack, whilst the lateral load was applied

using an actuator with 100 ton loading capacity (Figure 9). The displacement controlled loading sequence consisted of drift-controlled mode at drift increments of 0.25% until reaching 2% drift, and then followed by drift increments of 0.5%. Two cycles of loading were used in each drift ratio to ensure that the hysteretic behaviour could be maintained. Discrete load stages were defined where lateral loading was held constant whilst LVDT and strain gauge measurements were taken, crack patterns recorded, and visual inspections made. The test ended when the column lost the capacity to resist axial load rather than when peak lateral loading capacity of specimen was reduced by 20%.

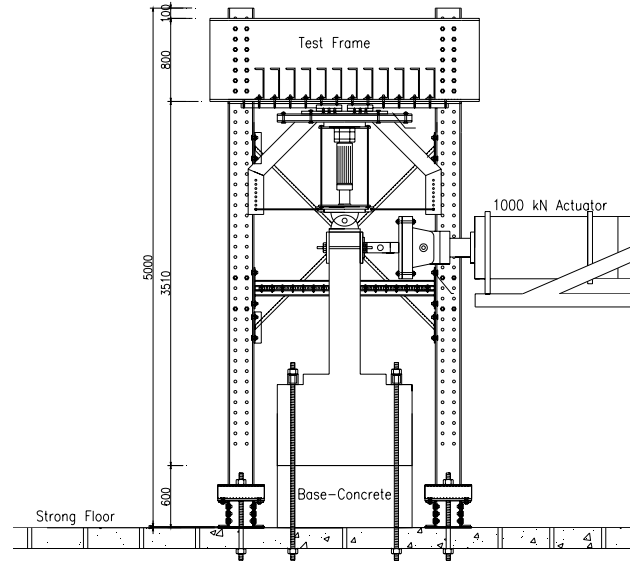
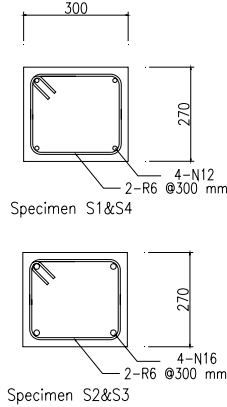
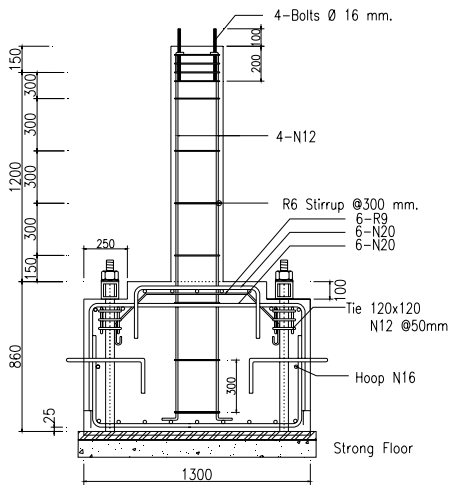

Figure 8 Geometry and reinforcement details of column specimens

Figure 9 Setup of Loading Test

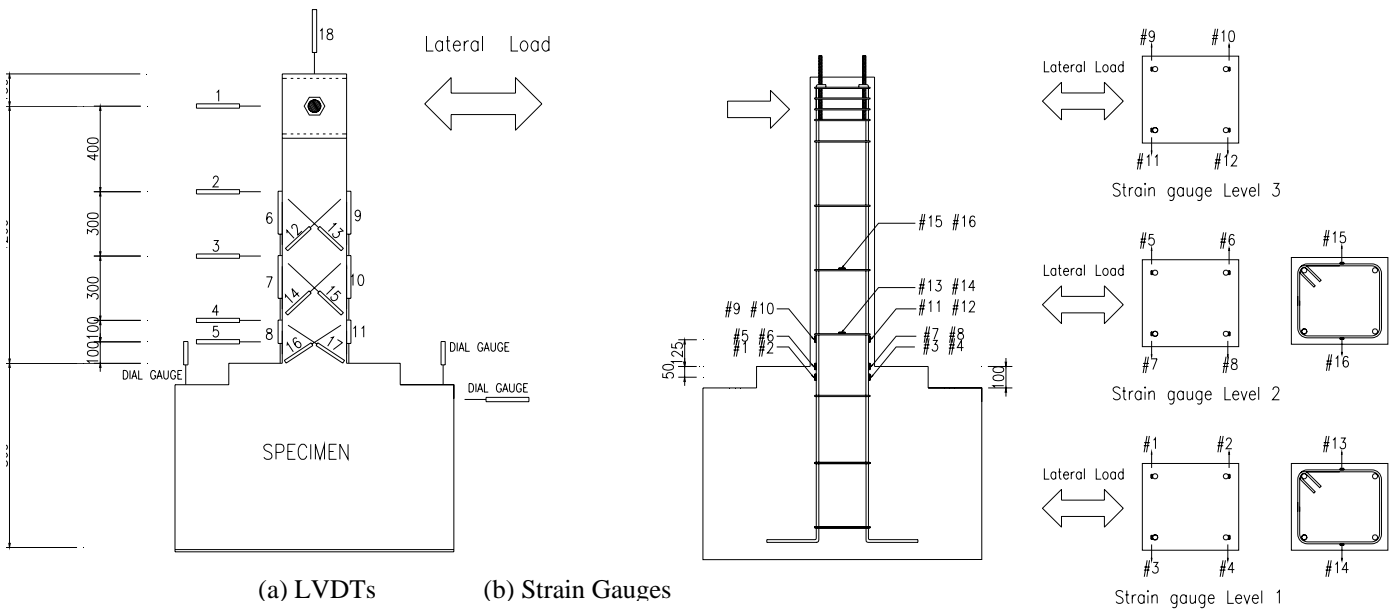

Figure 10 Instrumentation

Table 2 Basic Property of Column Specimens

Spec	Dimension (mm)	a (mm)	AR	ρ_v (%)	Main Rebar	ρ_H (%)		Ties (@mm)	n	f'_c (MPa)	Hook type
						area	volumetric				
S1	270×300×1200	1200	4	0.56	4N12	0.07	0.09	R6@300	0.2	20.3	135°
S2	270×300×1200	1200	4	1.0	4N16	0.07	0.09	R6@300	0.2	21.0	135°
S3	270×300×1200	1200	4	1.0	4N16	0.07	0.09	R6@300	0.4	18.4	135°
S4	270×300×1200	1200	4	0.56	4N12	0.07	0.09	R6@300	0.4	24.2	135°

Notation : a is the shear span which is the clear-height of the column in this case, AR is the shear span-to-depth ratio defined as shear span divided by the column depth (300mm), n is the axial load ratio (ratio of the axial load to axial load-carrying capacity or $A_c f'_c$), ρ_v is the longitudinal reinforcement ratio, ρ_H is the lateral reinforcement (A_{sh}/bs), A_{sh} = total area of transverse reinforcement; s = tie spacing; and b = column section width (270mm).

3.3 Experimental Results

Under gravity collapse load, specimen S1 with 0.56% rebar ratio and 20% axial load ratio was able to sustain a maximum drift of 5% with classical plastic hinge formation at the base of the column together with a rigid body rocking mechanism as shown in Figure 11(a). Such desirable behaviour is associated with yield penetration at the base allowing the joint to open and close rather than cracking and spalling of the concrete above the base.

In contrast, specimens S2 and S3 with almost twice the longitudinal reinforcement tolerated lower maximum drifts of 2.5% and 1.5% for axial load ratio of 20% and 40%, respectively. While the analytical formulae predicted flexural failure, the large tie spacing (300 mm) in these specimens lead to buckling of longitudinal bars ($\phi 16$ mm) and an abrupt transfer of axial load from the steel bars to the concrete. This triggered shear failure due to the deterioration of concrete strength during the cyclic loading as can be seen in Figure 11(b) and 11(c). Meanwhile specimens S4 and S3, both with an axial load ratio of 40% responded in a similar fashion with a maximum drift ratio of 1.5%, despite the different rebar ratio.

A summary of the test results is compiled in Figure 11(e) and Table 3, whilst the hysteresis curve for each specimen is presented in Figure 11(f). The lateral load and drift at failure corresponding to gravity axial load collapse are presented together with the drift values at 20% drop in the maximum lateral load-carrying capacity.

As indicated in Table 3, an increase in the axial load ratio from 0.2 to 0.4 resulted in an increase in ultimate lateral load by about 30%, whilst an increase of main rebar ratio from 0.56% to 1% increased the ultimate lateral load by about 10%. In contrast, an increase of axial load ratio from 0.2 to 0.4 reduced the ultimate drift capacity for 0.5% rebar ratio by about 70% compared with a 40% drift reduction for the 1.0% rebar ratio specimens.

All specimens exhibited classical R/C column behaviour up to the peak strength, with the maximum lateral load for the same axial load ratio occurring at a similar drift. The post peak behaviour of Specimen S2, S3, and S4 could be predicted using classical moment-curvature relationship, whereas specimen S1 had a much greater drift capacity than predicted.

The post-peak lateral load-drift behaviour of Specimen S1 (0.56% rebar ratio and 0.20 axial load ratio) was similar to a rocking mechanism where the column rocked on its edge. However, the column under extreme loading experienced spalling of the concrete cover, resulting in exposure and buckling of the longitudinal reinforcement which in turn further damages the concrete section. The response is not dissimilar to the precast soft storey tests with weak connections where rocking dominated and the R/C columns were undamaged (Section 3).

The post-peak behaviour of specimen S2 with 20% axial load ratio was characterized by tensile yielding of the main rebar and fast propagation of a shear crack prior to spalling of the concrete cover and shear failure at 2.5% drift.

The failure of specimen S3 with 40% axial load ratio was characterized as compression-controlled mechanism since the axial load P and moment M were on the upper branch of the interaction diagram. The post peak behaviour involved the development of vertical cracks in the compressive concrete area, followed by spalling of concrete cover, and shear failure at 1.5% drift due to buckling of the longitudinal reinforcement. Specimen S4 with 40% axial load ratio and 0.56% rebar ratio suffered an abrupt loss of axial load capacity due to shear failure at 1.5% drift, similar to specimen S3 with 1.0% rebar.

Both failures of specimen S2 and S3 (1.0% rebar) occurred around the second stirrup above the column base with similar crack angles of about 45° . In contrast, the plastic hinge of specimen S1 with 0.56% main rebar ratio occurred at the column base, with a crack angle less steep than that of the 1% main rebar ratio specimen S2.

The hook length used in the transverse reinforcement of all specimens was about half of the required hook length. But interestingly, an opening hook was not observed in any specimen, suggesting that the stirrup spacing has a greater effect on column behaviour rather than the hook type and length in lightly reinforced columns.

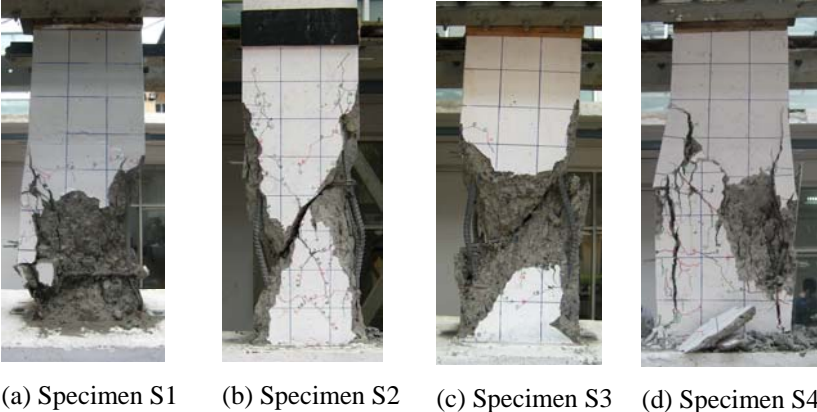

(a) Specimen S1 (b) Specimen S2 (c) Specimen S3 (d) Specimen S4

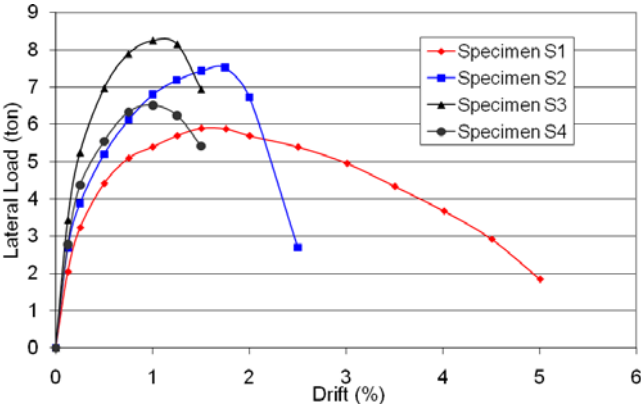

(e) The envelope curve of all specimens (normalized to f'_c 20MPa)

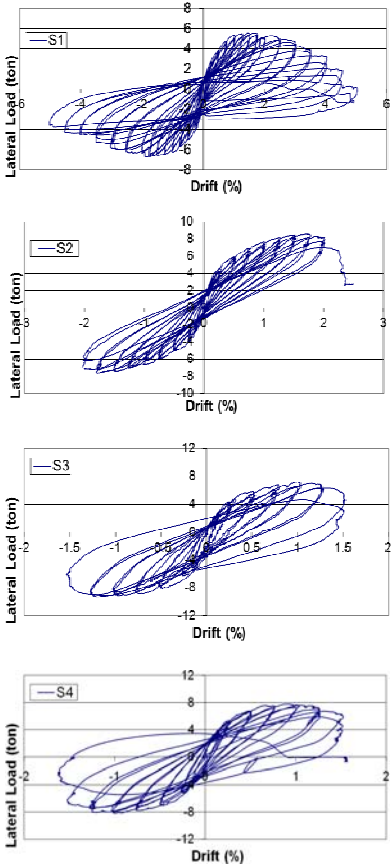

(f) Hysteresis Curve of each specimen

Figure 11 Results of Experiment Test

Table 3 Main Parameters resulted from the test (normalized to f_c' 20MPa)

	S1	S2	S3	S4
Maximum Lateral Load (kN)	59.7	75.1	82.5	63.7
Drift at maximum load (%)	1.71	1.73	1.12	1.01
Lateral load at 80% of peak load (kN)	47.7	60.1	66.0	52
Drift at 80% of peak load (%)	3.3	2.1	1.4	1.5
Lateral load at axial failure (kN)	16.1	28.3	50.1	52
Drift at axial failure (%)	5.01	2.5	1.5	1.5
Drift ductility	6.68	3.33	1.5	1.5

4. DRIFT CAPACITY ASSESSMENT

All results from the earthquake damaged building reconnaissance, the field-testing of a soft storey precast building, and experimental laboratory insitu column tests showed that non-ductile structure can sustain gravity axial load with drift capacity much higher than code recommendation. This is particularly important for low-to-moderate seismic regions context such as Australia.

Traditionally, performance assessment of a structure is based on trading-off the strength demand with ductility demand. In regions of high seismicity, structures are typically designed and detailed to accommodate large displacements without significant lateral strength degradation during an earthquake. Moreover, the design provisions are based on the concept of conservation of energy, as the kinetic energy developed in the responding structure must be absorbed and dissipated in a controlled fashion. Design guidelines that have been developed in regions of high seismicity (ATC40, FEMA 273) recommend a lower drift capacity for such strength degraded structures (Figure 12). Furthermore, the application of such standards in low and moderate seismic regions such as Australia, results in many of the strength degraded structures (such as soft storey structures, unreinforced masonry structures and rigid body objects) being deemed unsafe in an earthquake.

In a small and moderate magnitude earthquake, the velocity demand subsides as the natural period of the structure increases. The displacement demand on the structure can become insensitive to its natural period when the maximum displacement demand has been reached (Lam et al., 2005). Consequently, the survival of the structure is dependent on the displacement capacity as opposed to its energy absorption capacity. This phenomenon is known as displacement controlled behaviour (Figure 13). By this phenomenon structures can be deemed seismically safe, if their displacement capacity exceeds the imposed displacement demand irrespective of its strengths and energy dissipation capacity.

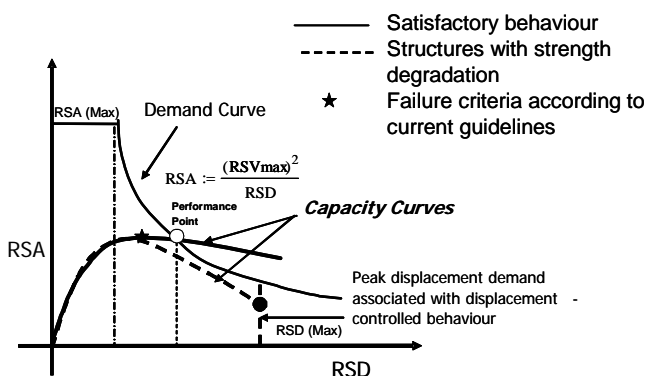

Figure 12. Capacity spectrum method.

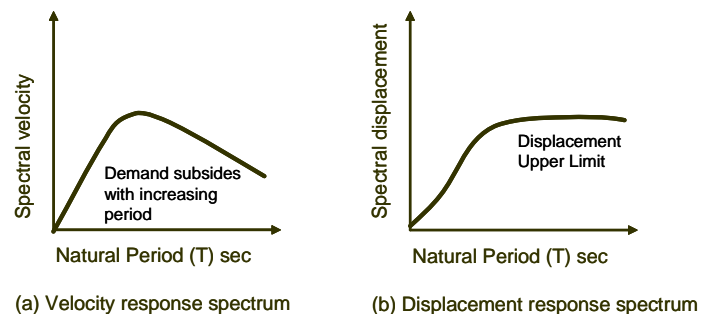

Figure 13. Displacement controlled behaviour

5. CONCLUSIONS

Field reconnaissance studies of damaged structures, experimental field-testing of precast soft storey buildings and experimental laboratory tests on insitu lightly reinforced columns have been undertaken in order to investigate the drift capacity and load-deformation behaviour of non-ductile soft storey structures.

The large drift capacity of the precast soft storey structure was surprisingly attributed to the weak connections which allowed the columns to rock at each end. Interestingly, the lateral strength capacity would have increased significantly if the column end connections were as strong as the members, but the drift capacity would have reduced substantially since the rocking mechanism would have been prevented forcing the columns to deform inelastically in shear and flexure. Hence, the precast soft storey construction resulted in a weaker structure with far greater drift capacity compared with a more traditional in-situ reinforced concrete structure. However, the ultimate drift capacity of cast in-situ lightly reinforced columns was still found to be greater than 1.0% for all specimens despite the poor detailing and high axial load ratios. Interestingly both the cast in-situ columns with very lightly reinforced concrete and low axial load ratio (specimen S1) and the precast columns with weak connections were both dominated by a rocking mechanism.

ACKNOWLEDGEMENT

The authors express their great thanks to A/Prof Ray KL Su and all the team from University of Hong Kong who assisted with the reconnaissance in China structural damage investigation and also provided valuable photos.

The authors also acknowledge the financial support from the ARC Discovery Grant #DPO772088 for the research undertaken and reported in this paper. The active support in completing field test from Delta Demolitions, the Office of Housing, and Fenton Partners, is gratefully appreciated. The authors are grateful to Dr. Phillip Collier and the postgraduate team from the University of Melbourne (Rupali S Bhamare, Elisa Lumantarna, Bidur Kafle, David Heath, Eldar Rubinov and Anna Donets).

The authors also express their grateful appreciation to Dr. Kittipoom Rodsin from King Mongkut's University of Technology and Prof. Panitan Lukkunaprasit and his team from Chulalongkorn University for invaluable assistance in conducting the experimental laboratory tests in Bangkok, Thailand.

REFERENCES:

- Bhamare R, Wibowo A, Gad EF, Collier P, Wilson JL, Lam NTK, and Rodsin K. "Field Testing of a Soft-Storey Building in Melbourne". *Procs. of Australian Earthquake Engineering Society Conference*; Ballarat, Australia, 2008, 21-23 November, paper no.48.
- Bhamare R, Lam NTK, Wibowo A, Wilson JL, Gad EF and Rodsin K. "Seismic Performance Assessment of Soft-Storey Buildings Based on Results from Field Testing." *Procs. of the 20th Australasian Conference on the Mechanics of Structures and Materials*, Toowoomba, Queensland, Australia; 2008,2 -5 December, pp 195-204.
- Bidur Kafle, Mohammad A. Kermani, Ari Wibowo. "A report on the visit to the region stricken by the Wenchuan Earthquake". 2008 Special Issue: Earthquake Engineering in the low and moderate seismic regions of Southeast Asia and Australia". *Electronic Journal of Structural Engineering*, Appendix B (Report), pp 1-31, 2008.
- FEMA-273. 1997. NEHRP guideline for the seismic rehabilitation of buildings. *Federal Emergency Management Agency*. Washington DC, USA.

- Ghannoum, W.M., Moehle, J.P., and Bozorgnia, Y. 2008. Analytical Collapse Study of Lightly Confined Reinforced Concrete Frames Subjected to Northridge Earthquake Ground Motions. *Journal of Earthquake Engineering*, Vol 12, pp 1105–1119.
- Lam, N., Wilson, J., Venkatesan, S. 2005. Accelerograms for dynamic analysis under the new Australian Standard for earthquake actions. *Electronic Journal of Structural Engineering*, Vol. 5: 10-35.
- Lam, S.S.E., Wu, B., Wong, Y.L., Wang, Z.Y., Liu, Z.Q. and Li, C.S. 2003. Drift Capacity of Rectangular Reinforced Concrete Columns with Low Lateral Confinement and High-Axial Load. *Journal of Structural Engineering*, ASCE, Vol. 129(6), pp.733-742.
- Moehle, J.P. 2008. Earthquake Collapse Risk of Older Concrete Buildings. *Proc. Luis Garcia Symposium*. Bogota, Colombia, May 2008.
- Otani, S. 1999. RC Building Damage Statistics and SDF Response with Design Seismic Forces. *Earthquake Spectra*, Earthquake Engineering Research Institute, Vol. 15, No. 3, pp. 485 - 501.
- Priestley, M.J.N., Verma, R., and Xiao, Y. 1994. Seismic shear strength of reinforced concrete column. *Journal of Structural Engineering*, ASCE, Vol. 120(8), pp.2310-2329.
- Sezen, H. and Moehle, J.P. 2004. Shear strength model for lightly reinforced concrete columns. *Journal of Structural Engineering*, ASCE, Vol. 130(11), pp. 1692-1703.
- Wibowo A, Wilson JL, Gad EF, and Lam NTK. 2010. Collapse Modelling Analysis of a Precast Soft-Storey Building in Melbourne. *Engineering Structural Journal*, Elsevier. Special Issue: Learning Structural Failures, Vol. 32(7), July, pp 1925-1936.
- Wibowo, A., Kafle, B., Kermani, A.M., Lam, N.T.K, Wilson, J.L., Gad, E.F. 2008. Damage in the 2008 China Earthquake. *Procs. of Australian Earthquake Engineering Society Conference*, Ballarat, Australia, 21-23 November.
- Wibowo A, Wilson JL, Lam NTK, Gad EF. “Modelling Precast Reinforced Concrete Columns and Comparisons with Results from Field Testings”. *Procs. of The 1st International Conference on Computational Technologies in Concrete Structures (CTCS’09)*, Jeju, South Korea; 2009, 24-27 May, pp 184.
- Wibowo A, Wilson JL, Gad EF., Lam NTK, Collier P. “Collapse Modelling Analysis of a Precast Soft-Storey Building in Melbourne”. *Procs. of Australian Earthquake Engineering Society Conference*; Newcastle, New South Wales, Australia, 2009, 11-13 Desember.
- Wibowo A, Wilson JL, Lam NTK, Gad EF, Fardipour M, Rodsin K, Lukkunaprasit P, “Drift Capacity of Lightly Reinforced Concrete”. *Procs. of Australian Earthquake Engineering Society Conference*; Perth, Australia, 2010, 26-28 November, paper no.51.
- Wibowo A, Wilson JL, Fardipour M, Lam NTK, Rodsin K, Lukkunaprasit P, Gad EF. “Seismic Performance Assessment of Lightly Reinforced Concrete”. *Procs. of the 21st Australasian Conference on the Mechanics of Structures and Materials*, Melbourne, Australia; 2010,2 –5 December, Paper no. 58.
- Wibowo A, Wilson, J., Lam, N., Gad, EF. 2010. “Drift Capacity of Precast Soft Storey Building in Melbourne”. *Australian Journal of Structural Engineering*, Manuscript Number: S10-076
- Wilson, J., Lam, N. 2003. “A recommended earthquake response spectrum model for Australia”. *Australian Journal of Structural Engineering*, Vol 5, No 1: 17-27.
- Wilson, J.L., Lam, N., Rodsin, K. 2009. “Collapse modelling of soft storey building”. *Australian Journal of Structural Engineering*, AJSE, Vol. 10, no 1, pp 11-23.
- Wilson, J., Lam, N. 2006. Earthquake design of buildings in Australia using velocity and displacement principles. *Australian Journal of Structural Engineering*, Vol 6, No 2: 103-118.
- Wilson JL, Wibowo A, Lam NTK, Fardipour M, Gad EF, Rodsin K, Lukkunaprasit P. “Drift Capacity of Lightly Reinforced Concrete”. *International Symposium on a Robust and Resilient Society against Natural Hazards & Environmental Disasters and the third AUN/Seed-Net Regional Conference on Geo-Disaster Mitigation*, August 24-26, 2010, Kyoto, Japan